

OPTIONAL included!

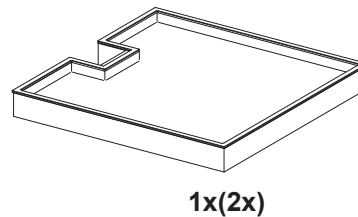
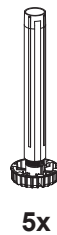
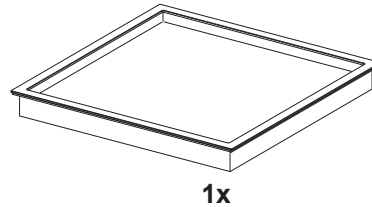

General assembly instructions

- Anyone who performs connection or assembly work on Qanto must have access to these assembly instructions. Follow these instructions. Non-observance of the abovementioned instructions can lead to accidents resulting in severe personal injury.
- Assembly may be performed by expert personnel only.
- If Qanto is not installed as a corner cabinet, ensure there is sufficient clearance from the edge of the counter.
- If the product is visibly damaged, it must not be installed.
- During the installation of Qanto, make sure there is sufficient clearance for the movement of the lifting system. When Qanto is extended upward and to both sides, a clearance of about 200 mm to other cabinets or shelving must be observed.
- A clearance of 300 mm must be observed between Qanto and a gas stove.
- The electrical system of Qanto must be accessible (e.g., a double socket under the cabinet near the base).
- Make sure the cables are undamaged.
- Before connecting the electrical drive to the in-house power mains, compare the voltage of the power mains with the input voltage specified on the type plate. The mains voltage and permissible input voltage must be identical. If not, Qanto must not be connected.
- If the control unit causes unusual noises or odours during operation, interrupt the power supply.

Notes

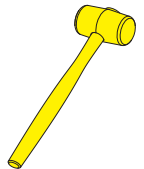
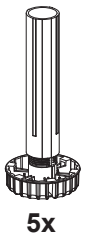
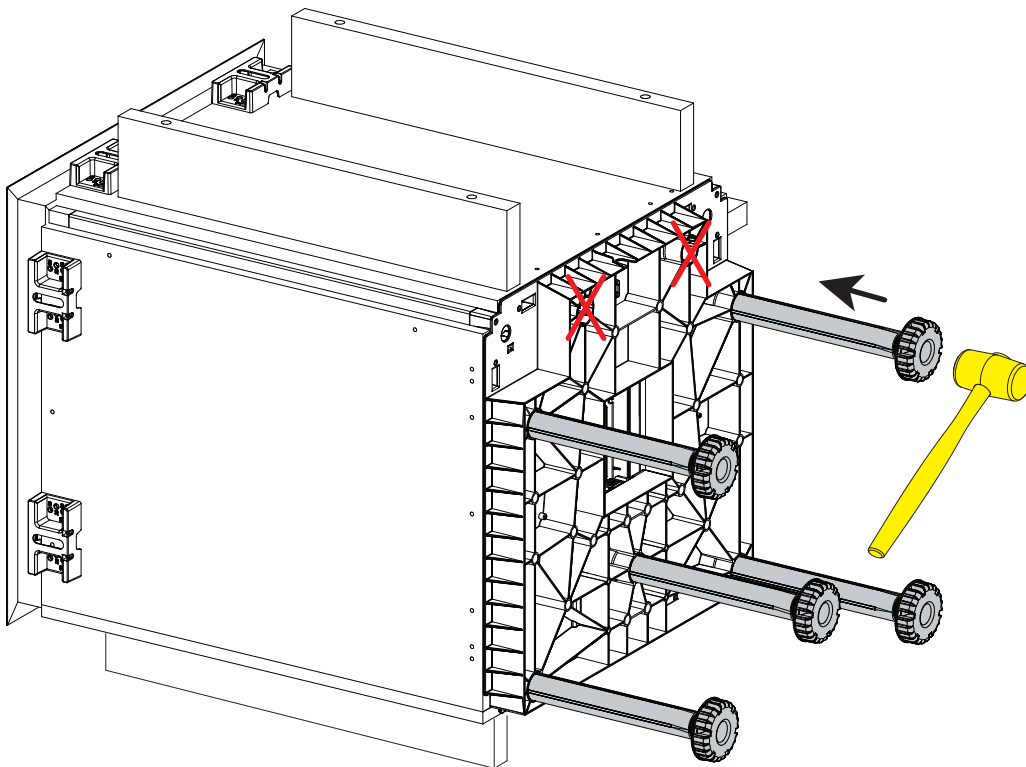
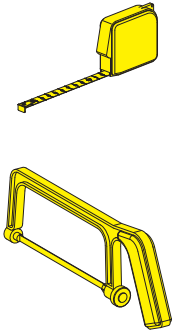
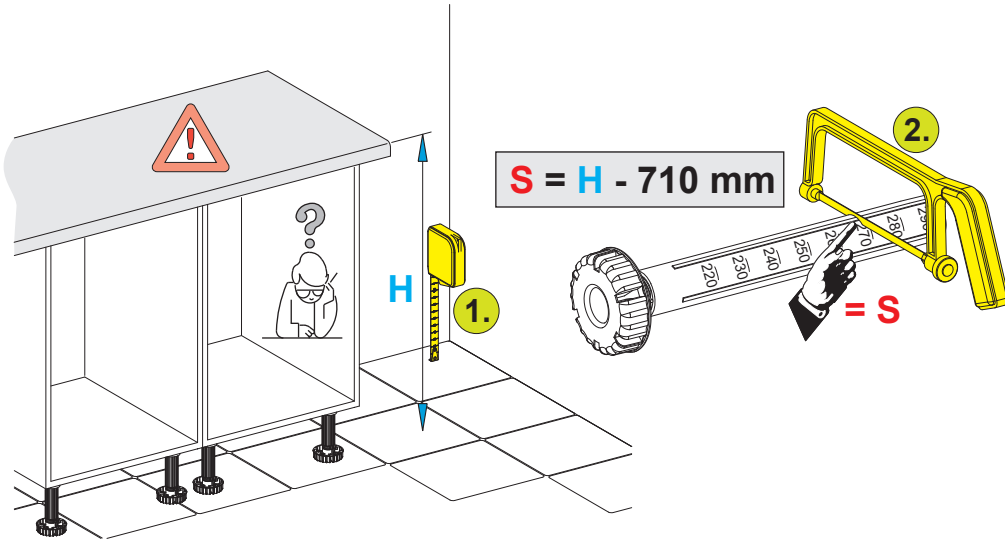

- AP = 39 mm
- AP = 29 mm
- AP = 20 mm
- AP = 16 mm
- AP = 13 mm

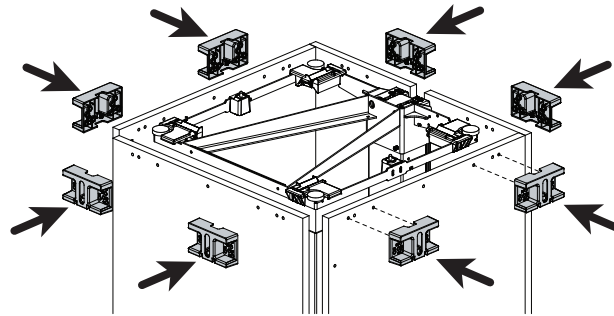
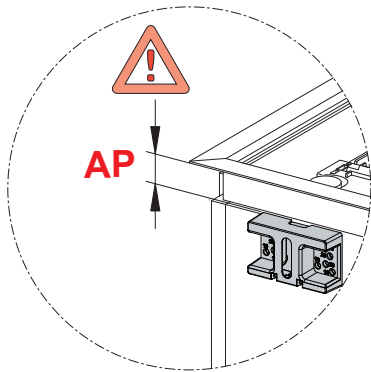
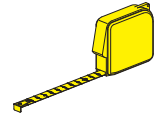
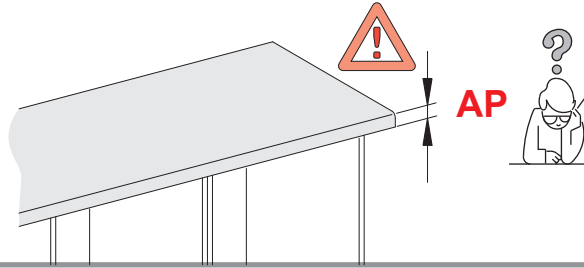

OPTIONAL included!

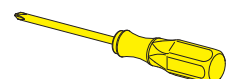
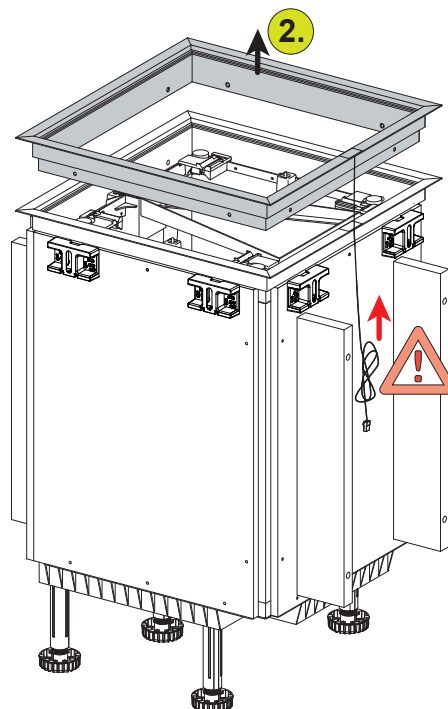
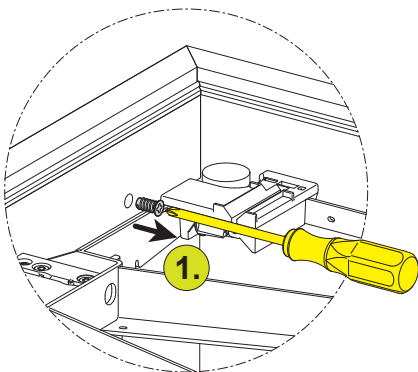
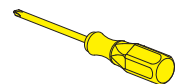
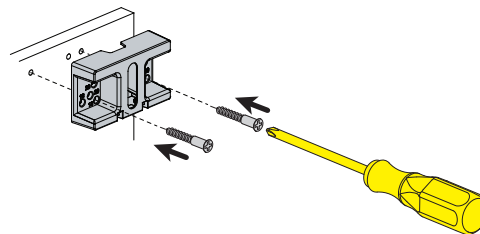
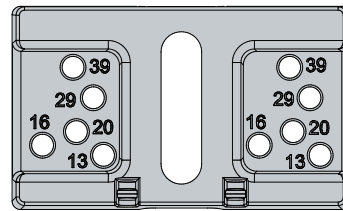
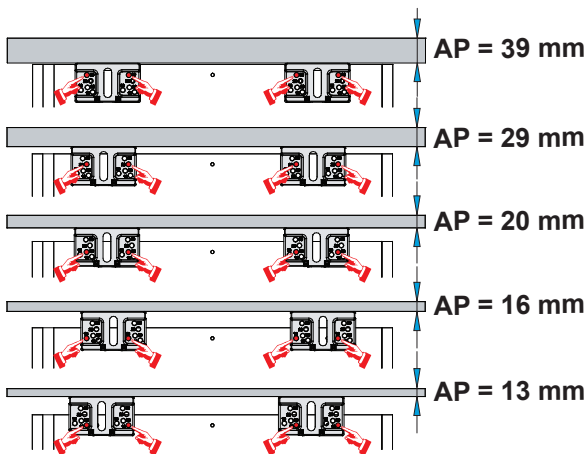
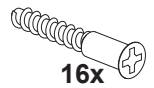
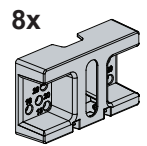

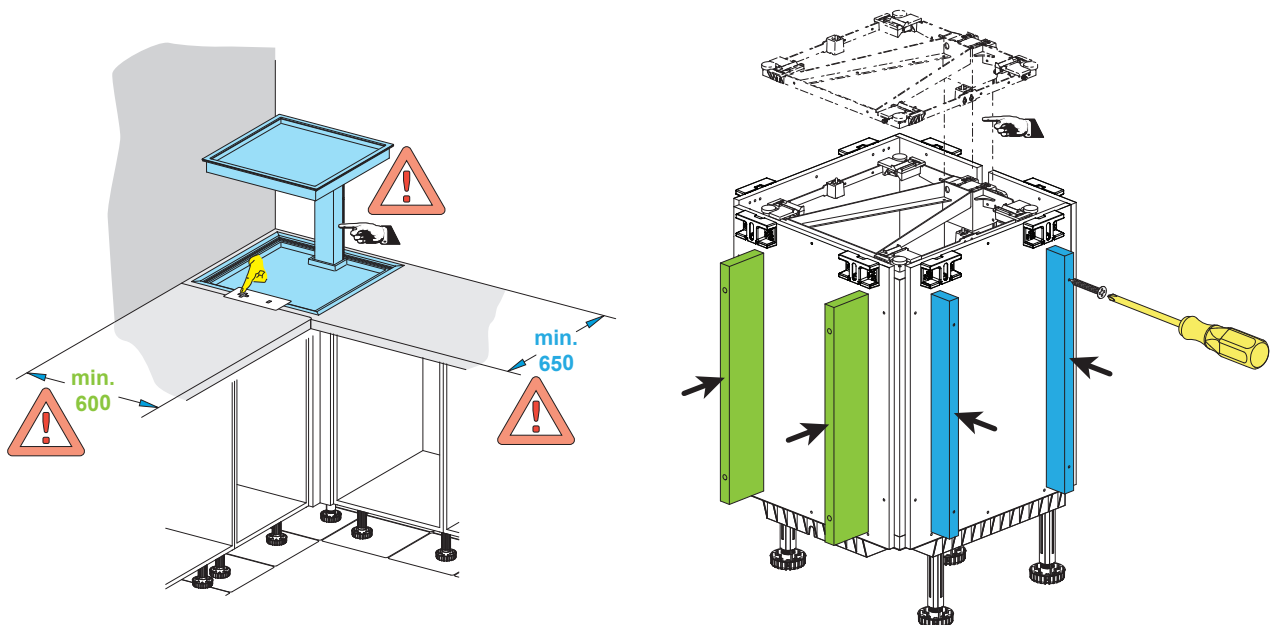
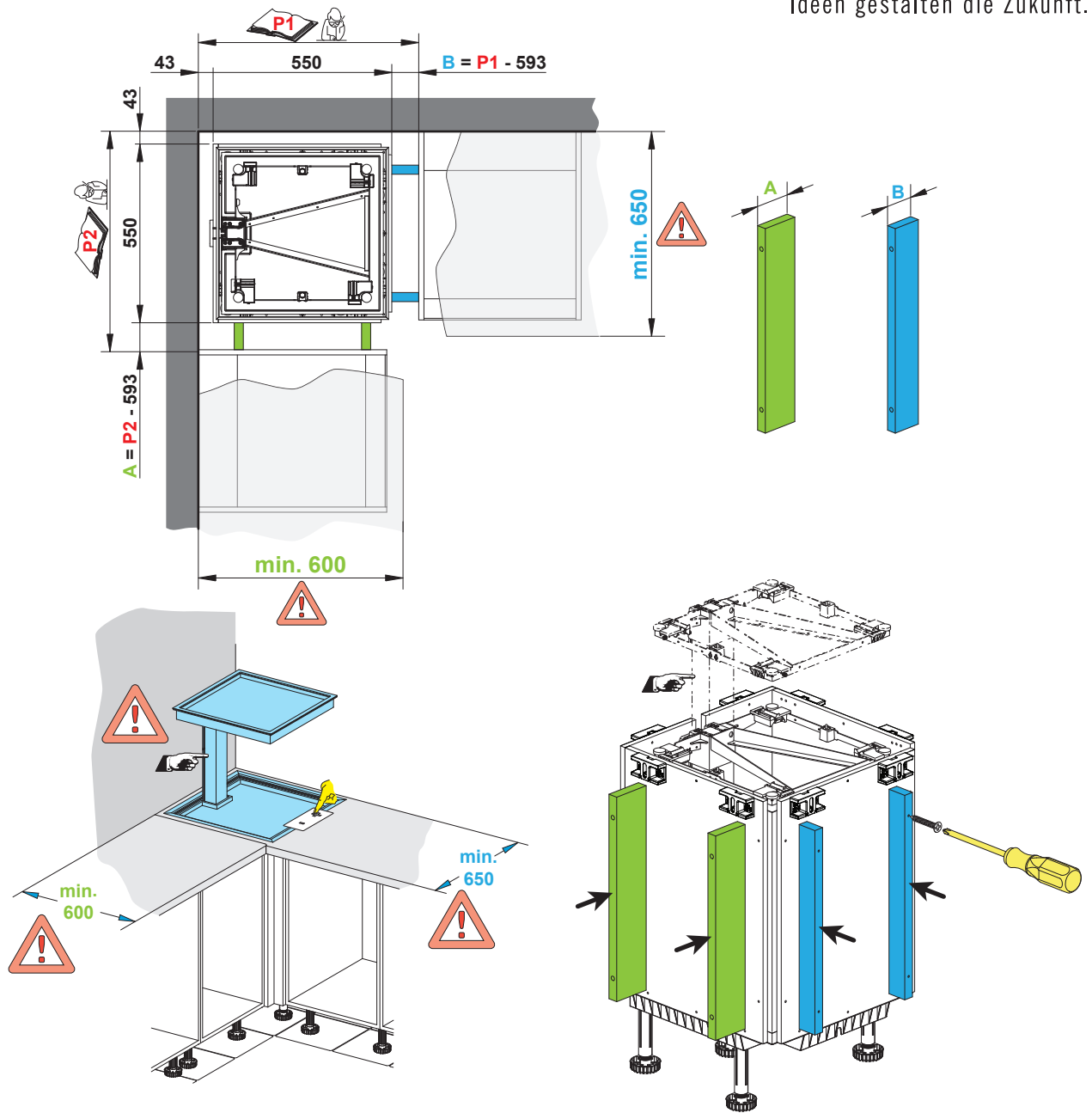

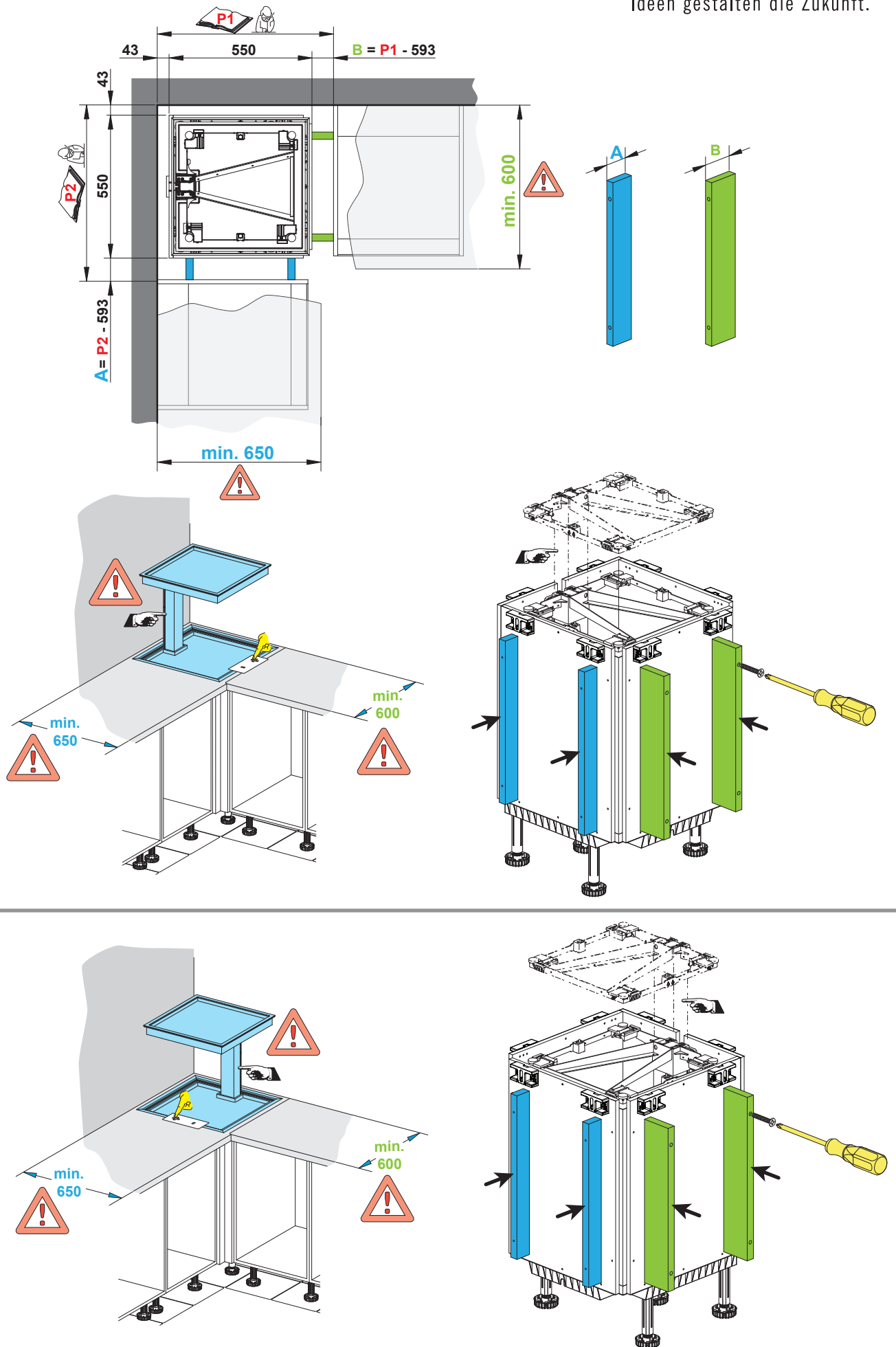

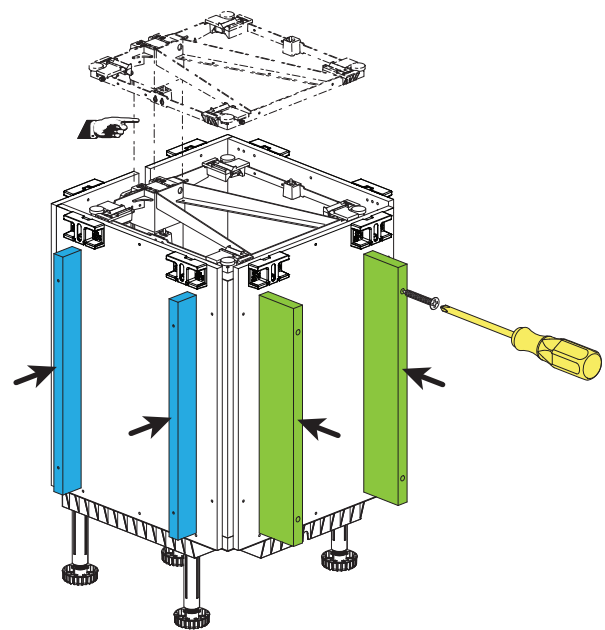
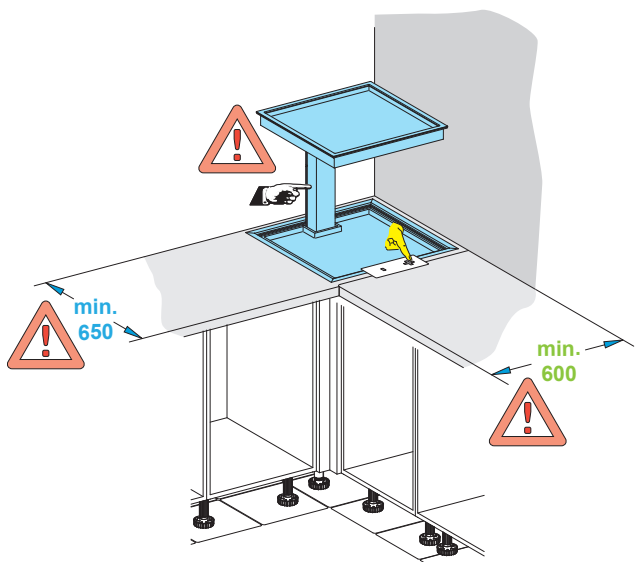
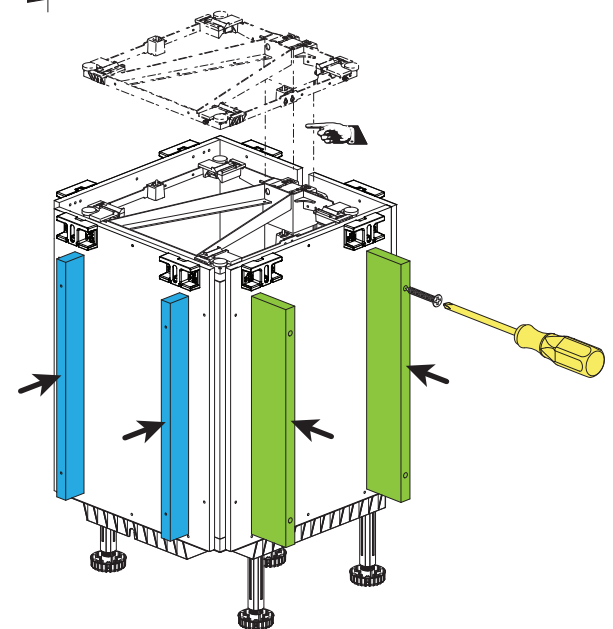
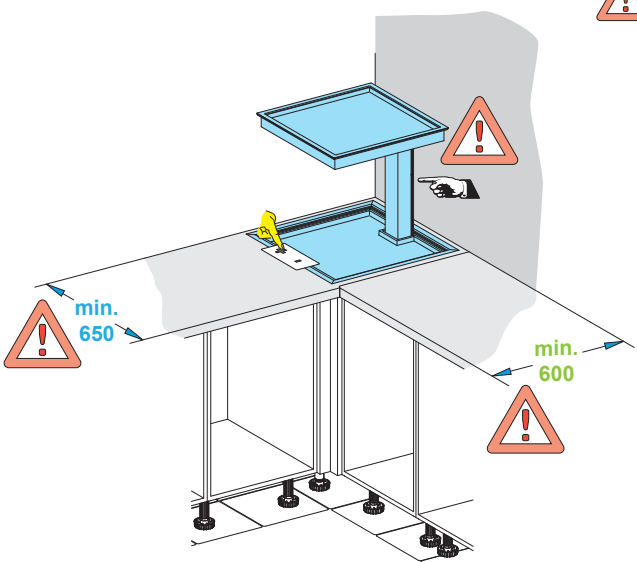
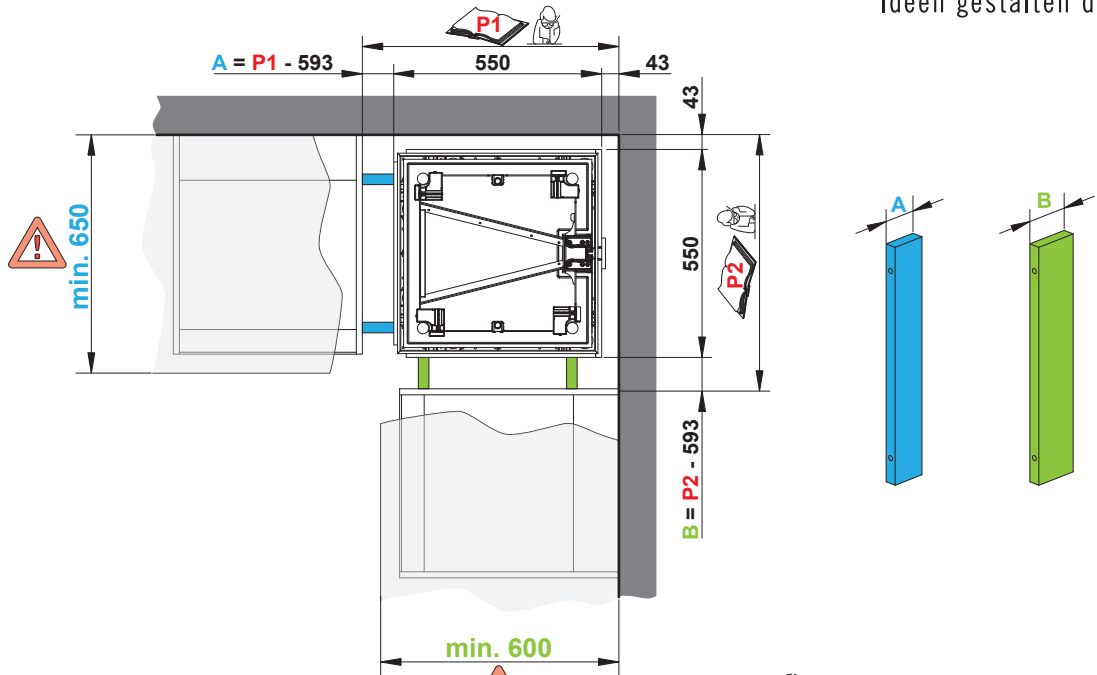

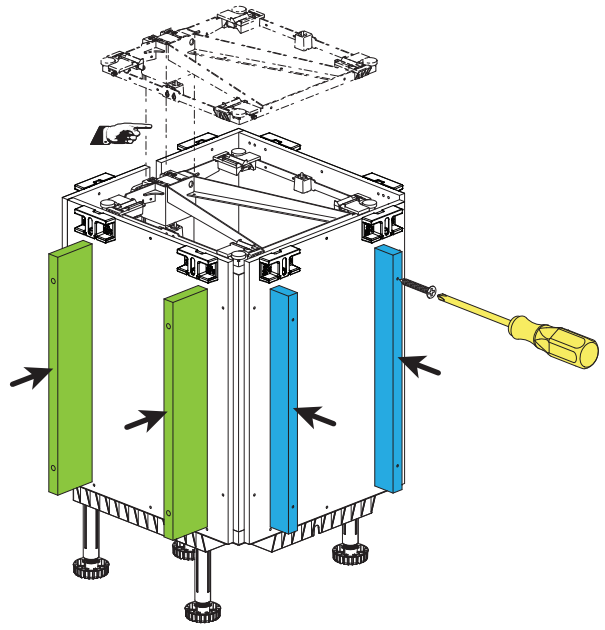
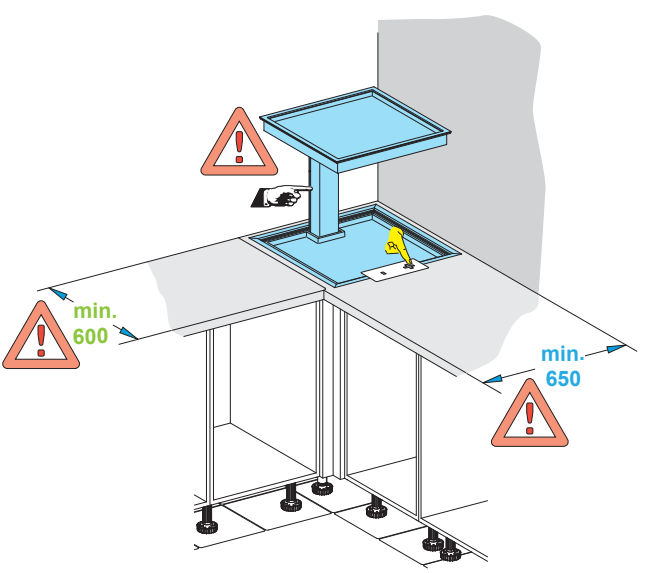
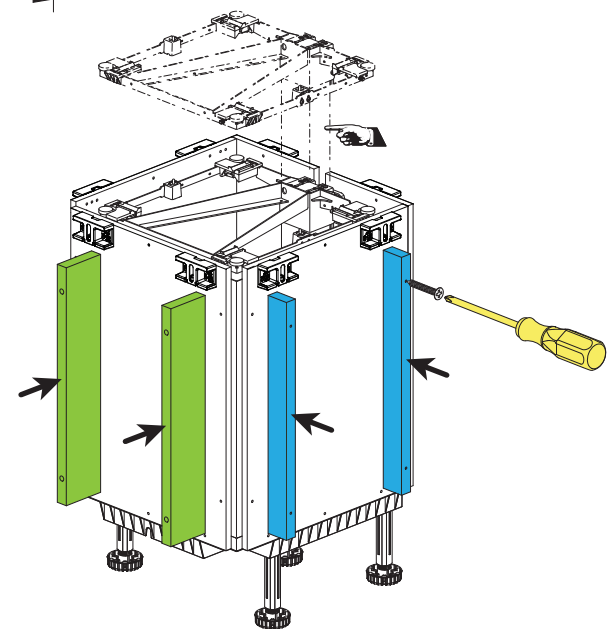
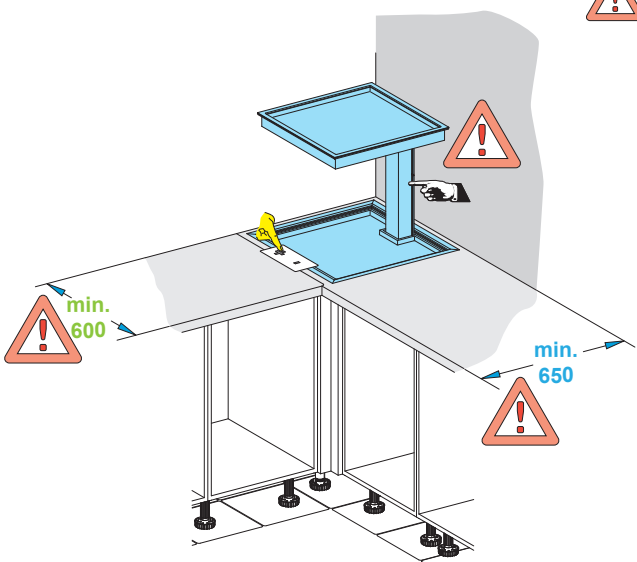
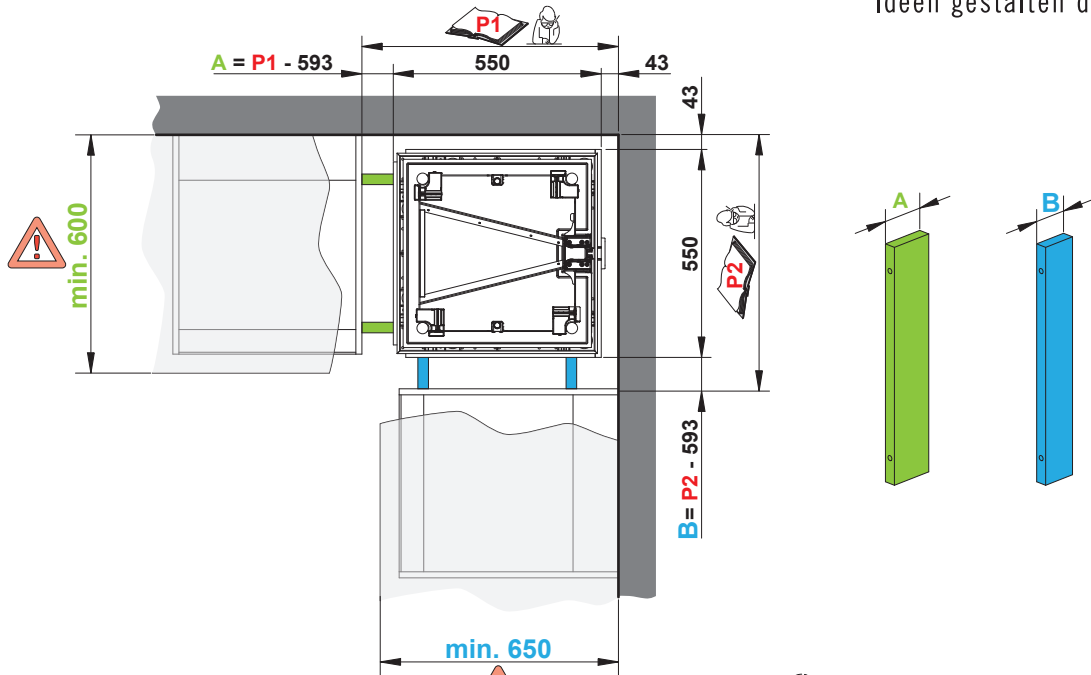

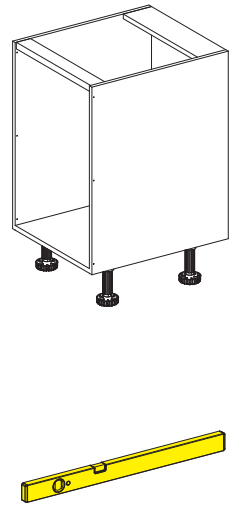
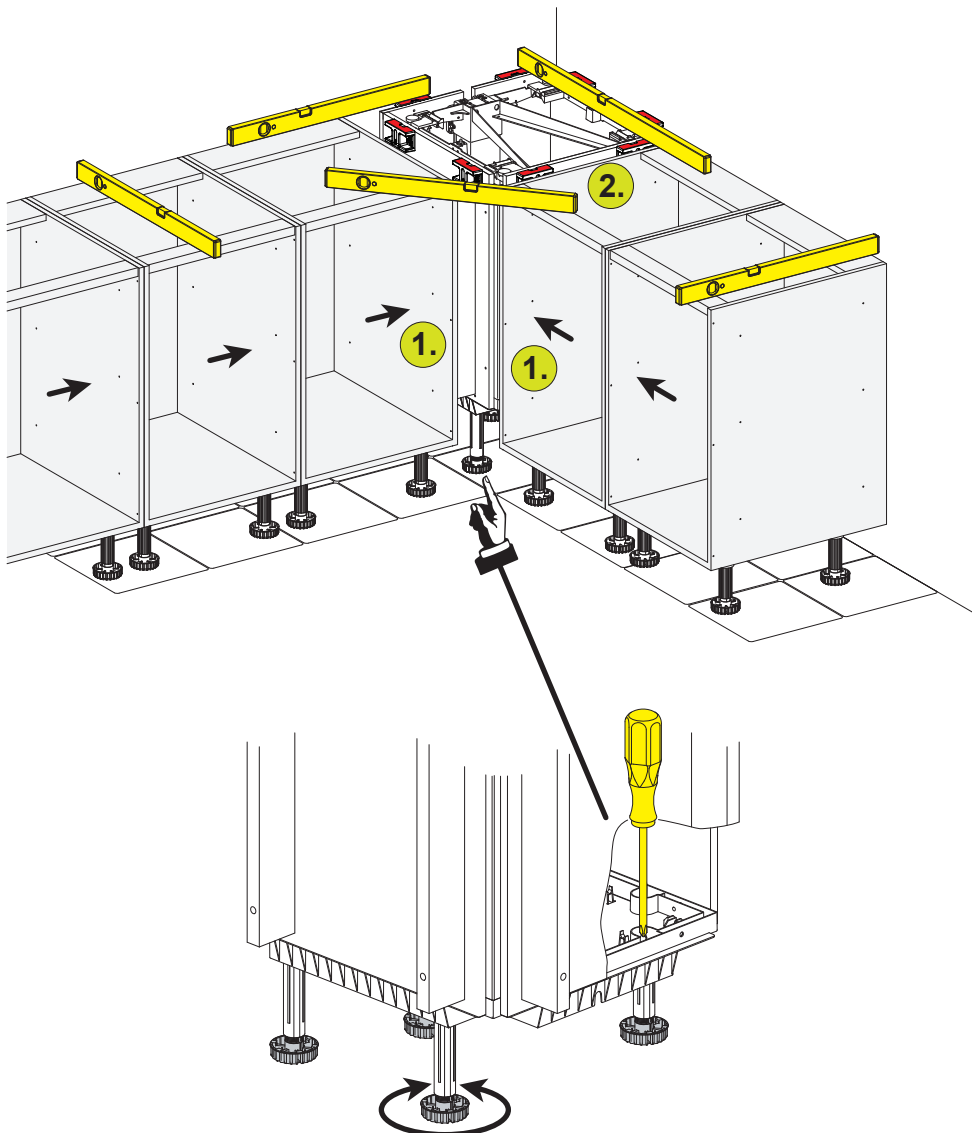
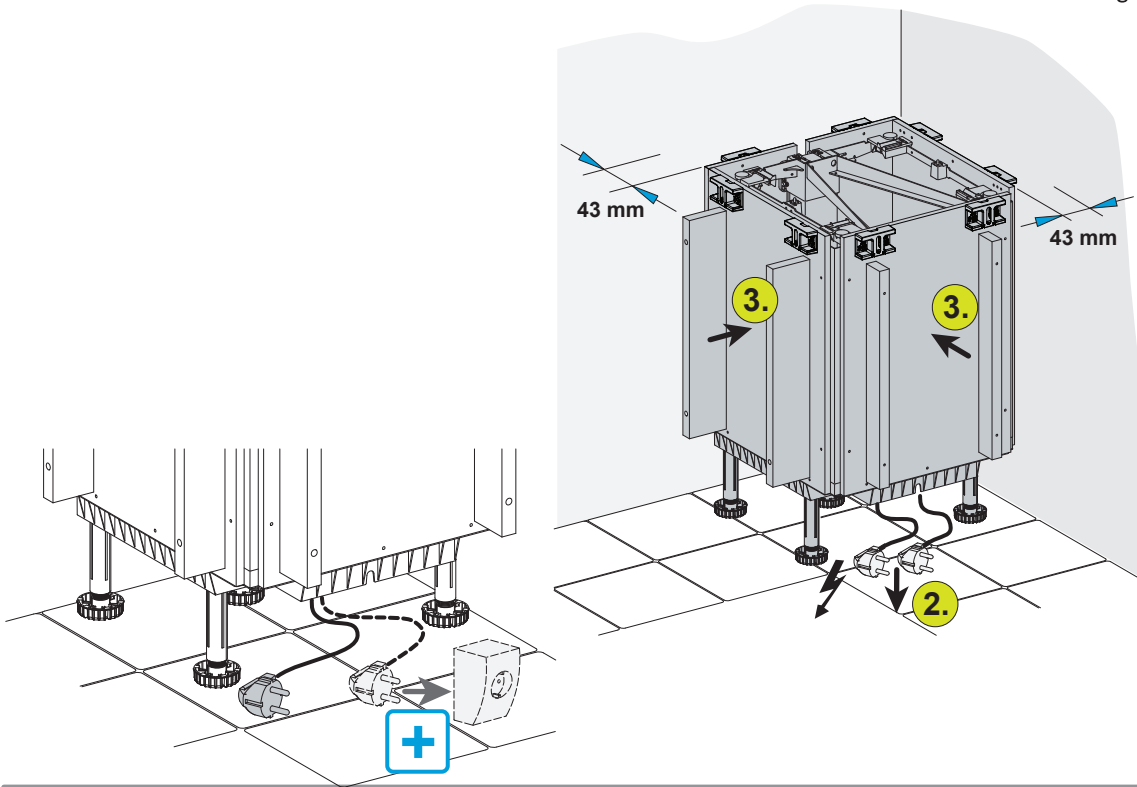

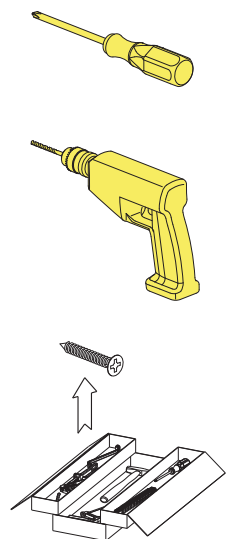
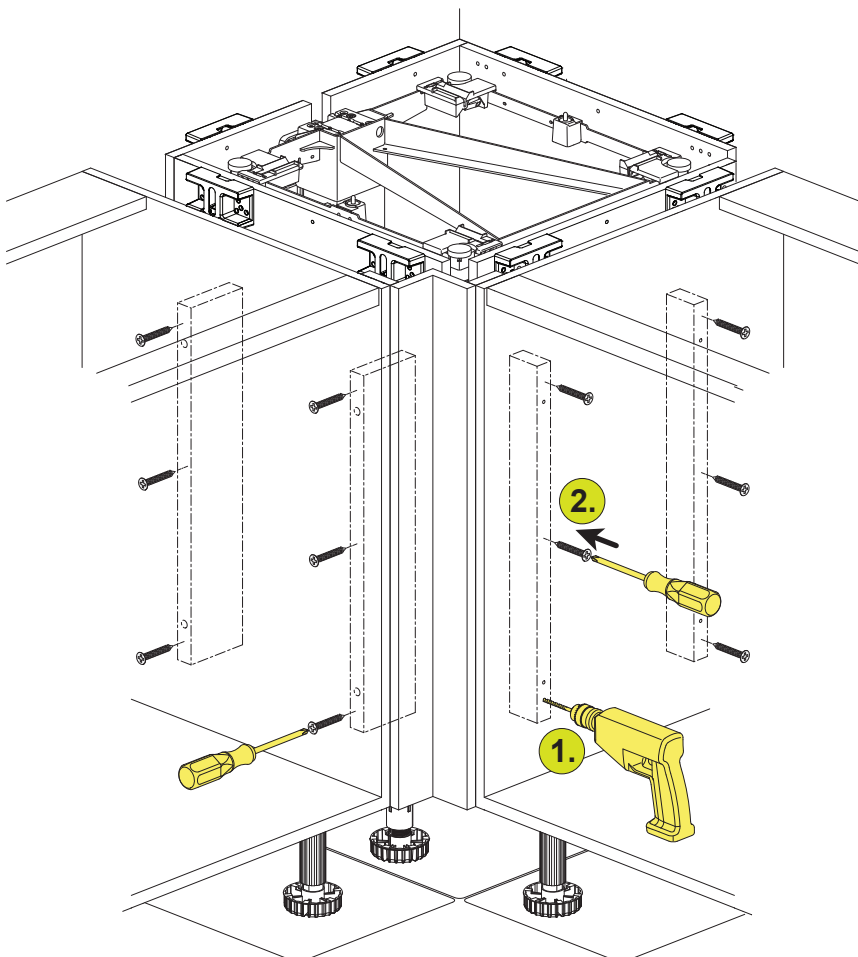
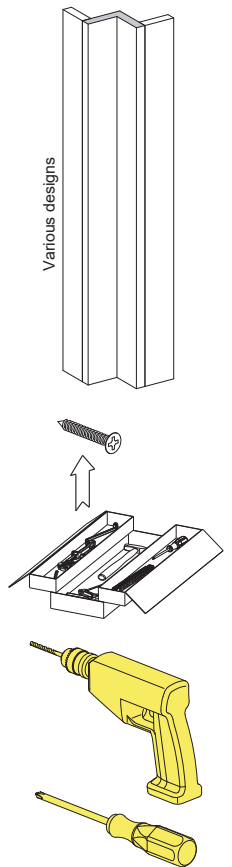
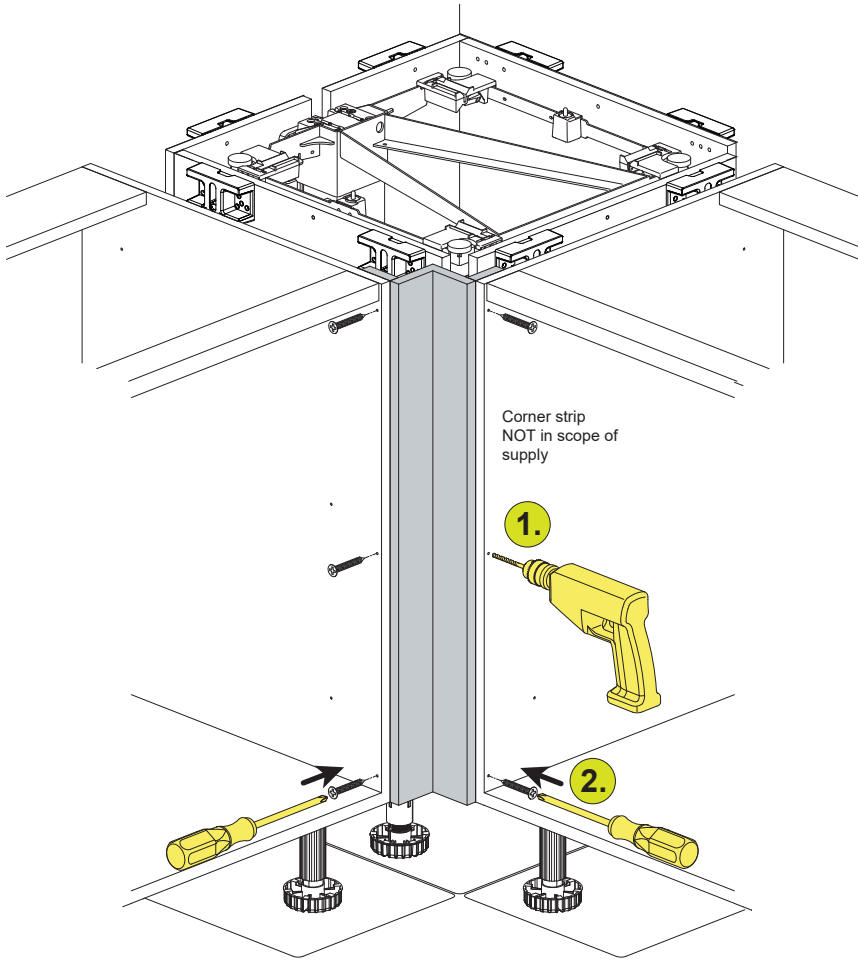

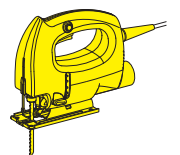
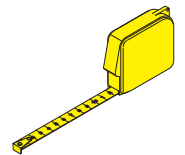
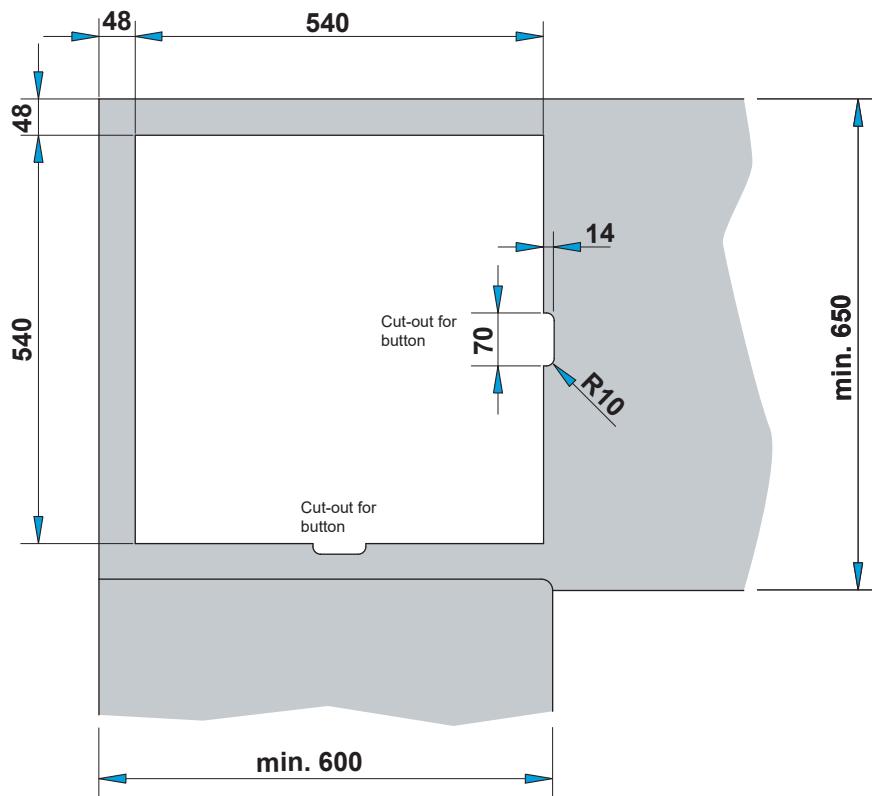
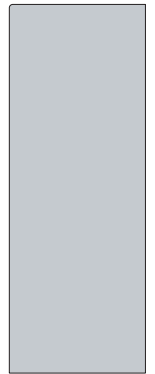
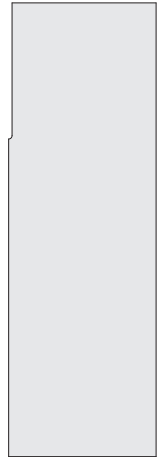
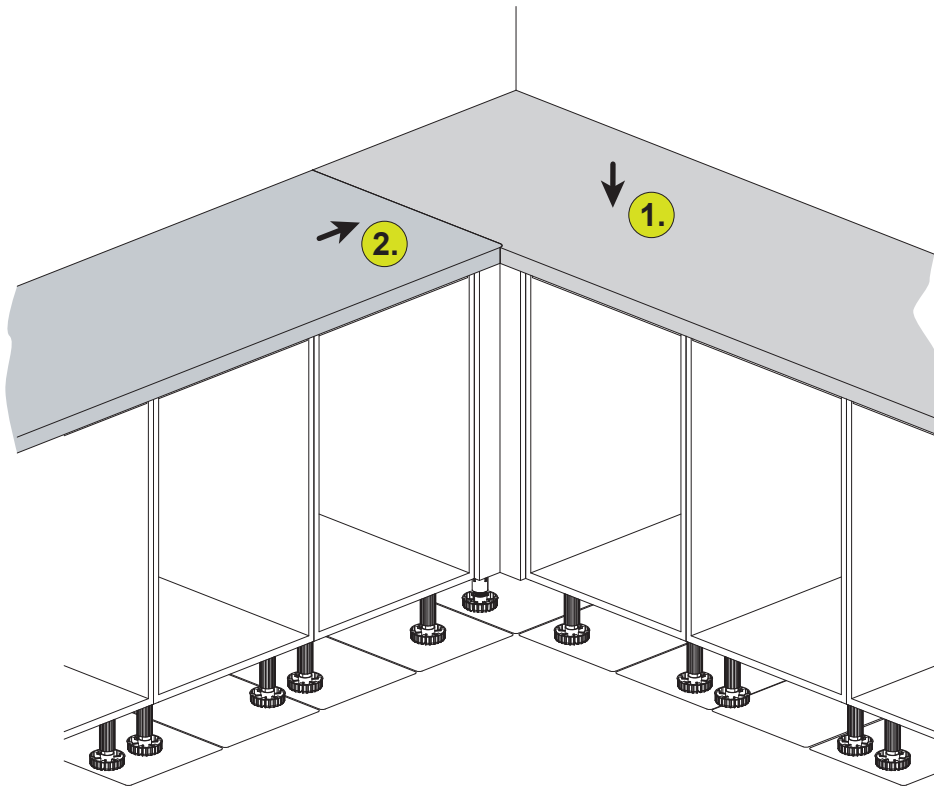

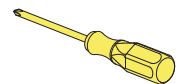
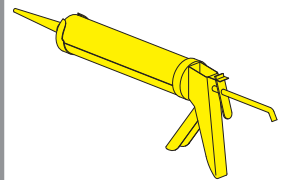
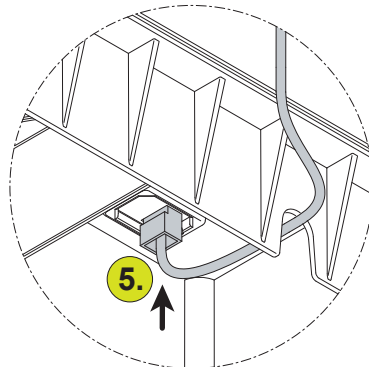
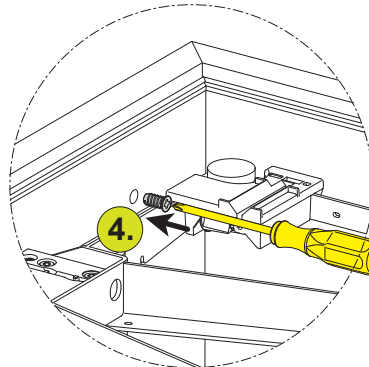
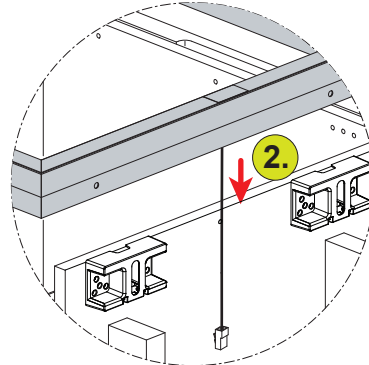
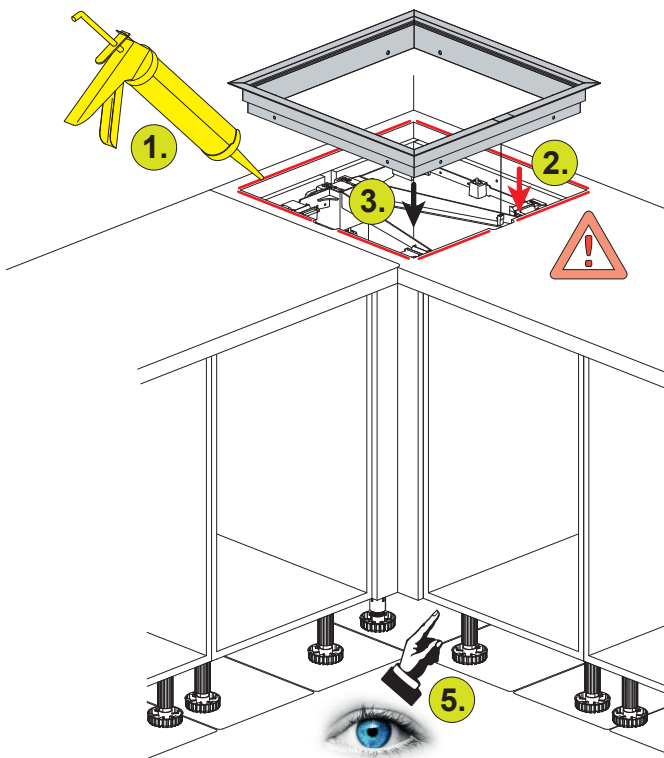
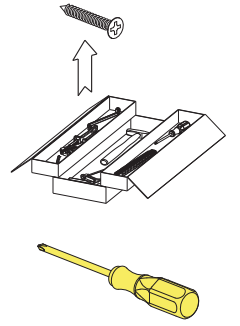
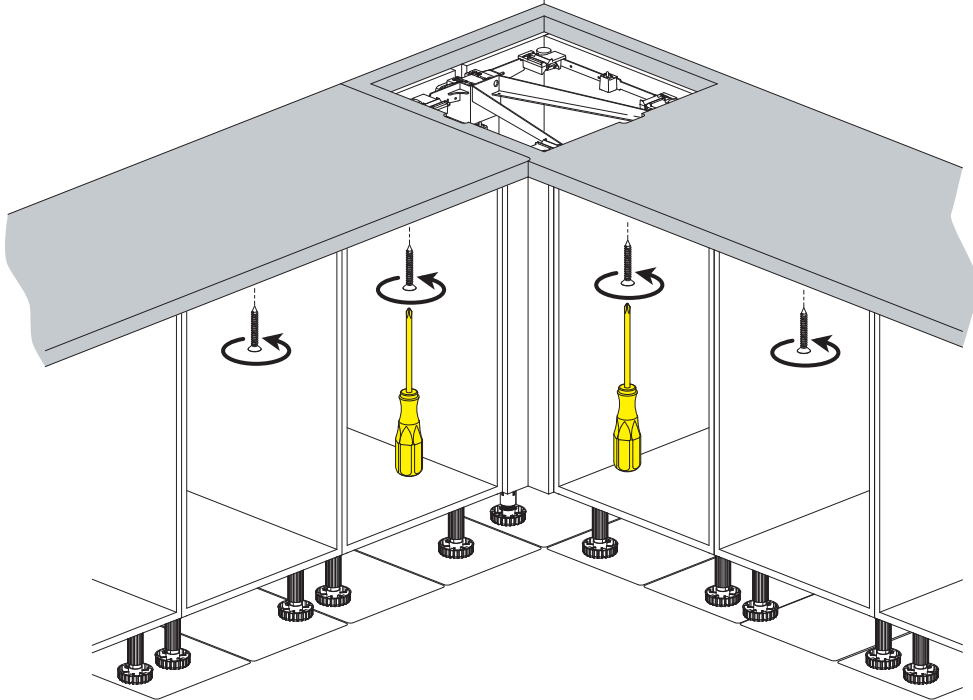

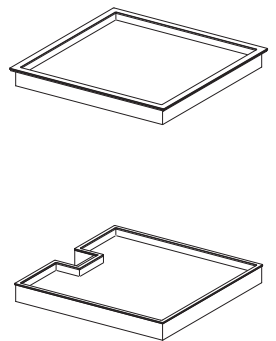
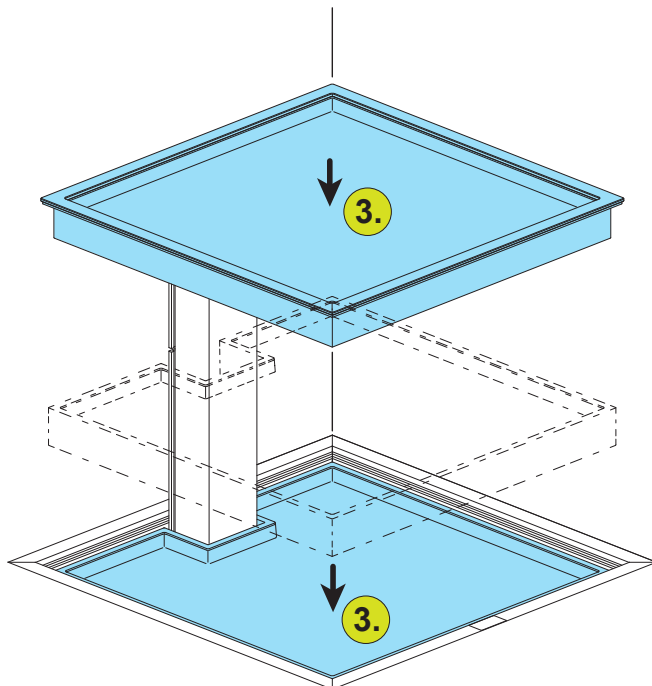
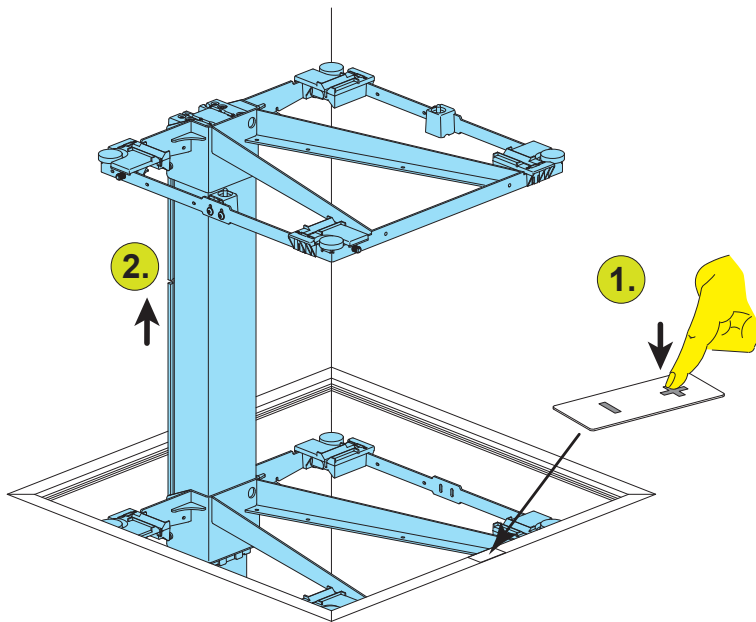

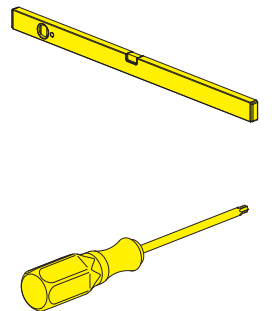
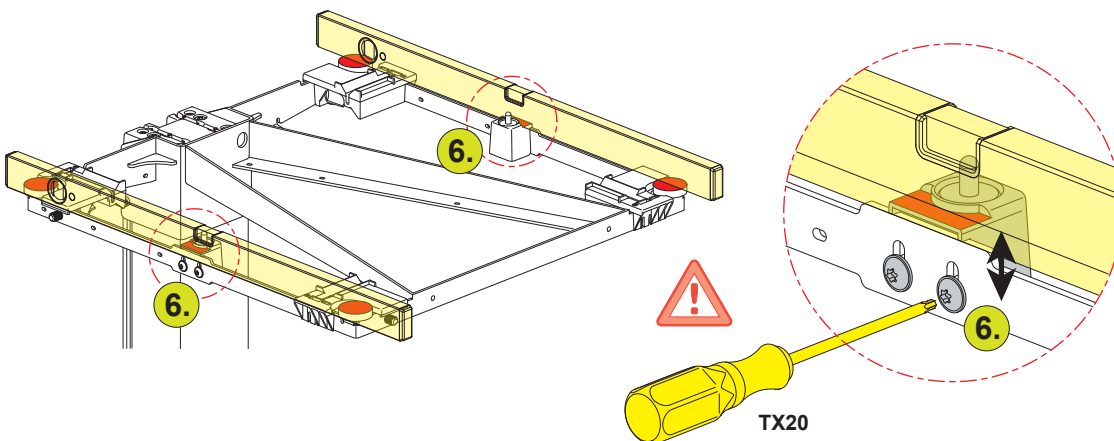
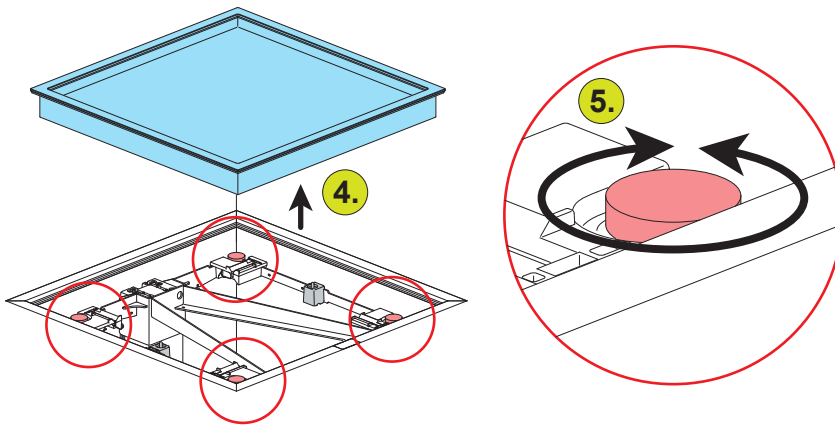
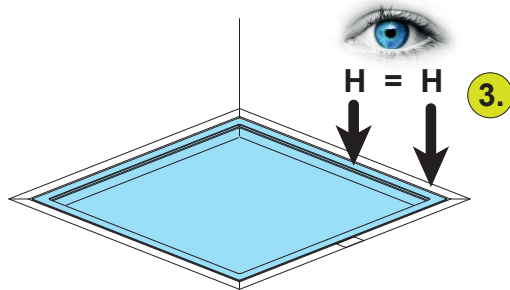
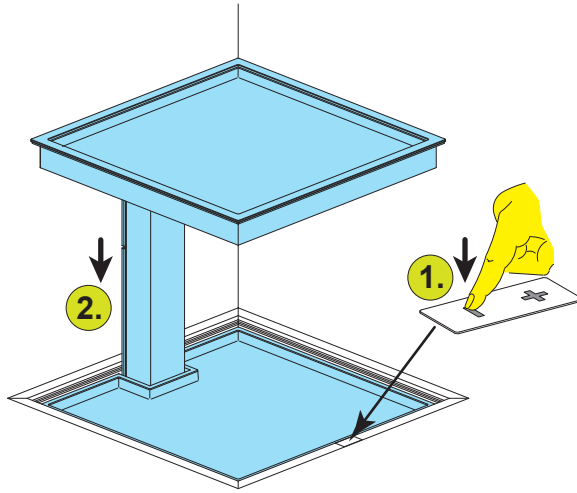

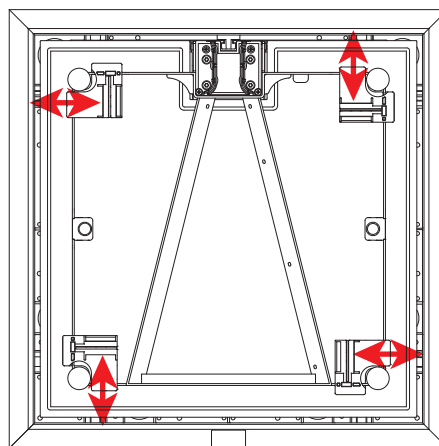
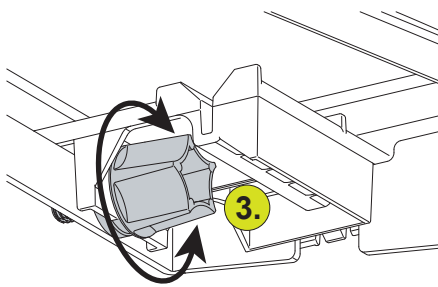
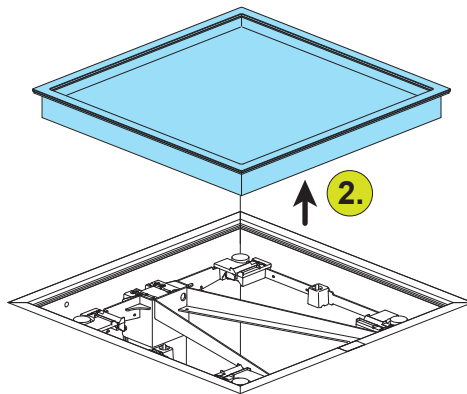
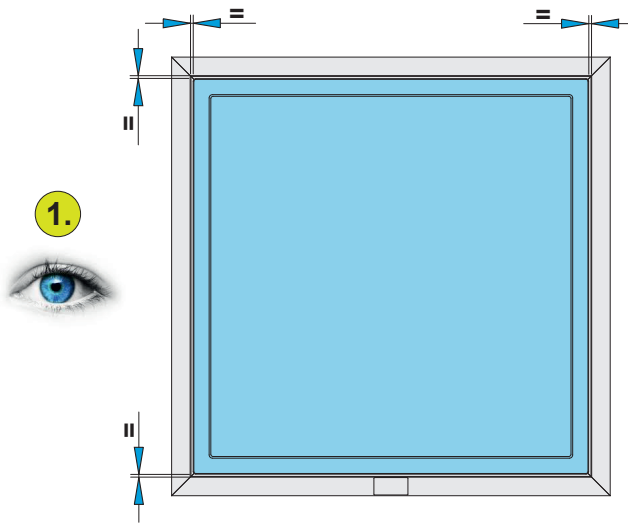

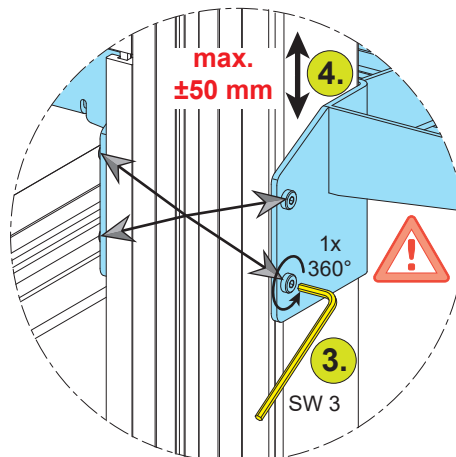
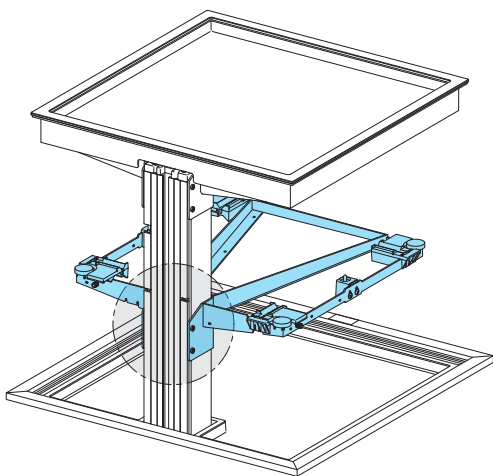
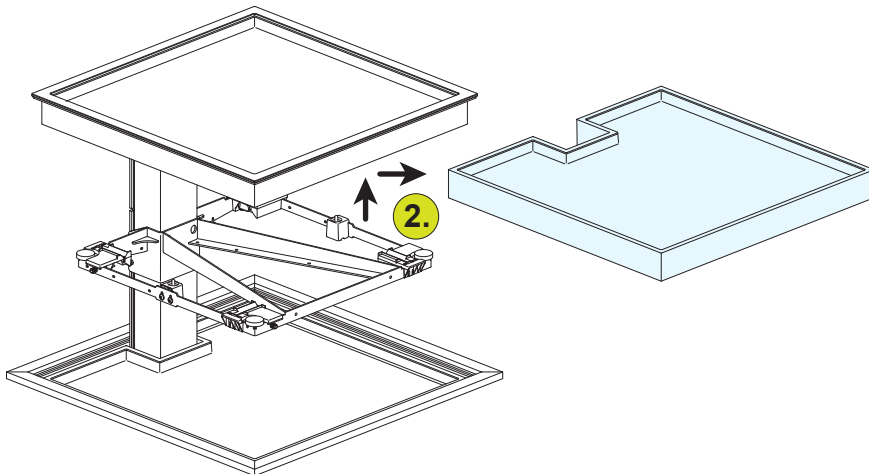
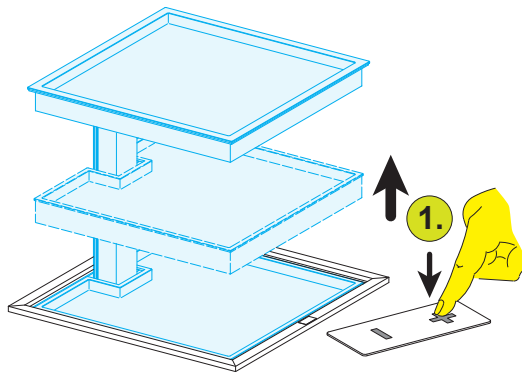

Notes



ninka®

Ideen gestalten die Zukunft.

We are gladly available in case of any questions.

Service number:

+49 (0) 5222 / 949494